

WORK
SCALE.
DESIGN

Ws.D Malin

CAFÉ AND BREAKOUT CHAIR





VERSATILE BREAKOUT SEATING

The moulded shell makes it suited for a range of workspaces

ITALIAN DESIGN

Designed by Claudio Bellini Design



BASE OPTIONS

- Sled Base
- 4-Star Base
- 4-Leg Base
- 4-Leg Wood Base
- Beam Seating







4-LEG BASE



4-LEG WOOD BASE



SLED BASE



4-STAR BASE



4-STAR WITH CASTORS



2-POSITION BEAM



3-POSITION BEAM



4-POSITION BEAM



5-POSITION BEAM

DIMENSIONS

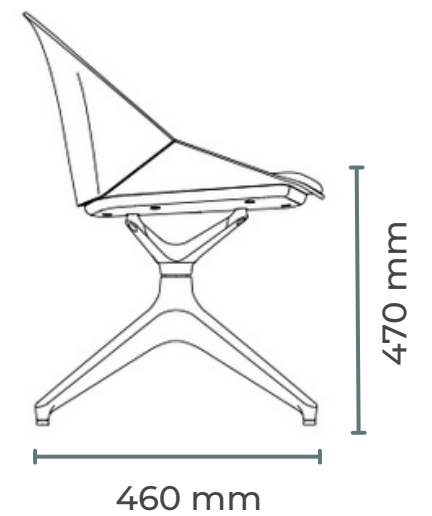
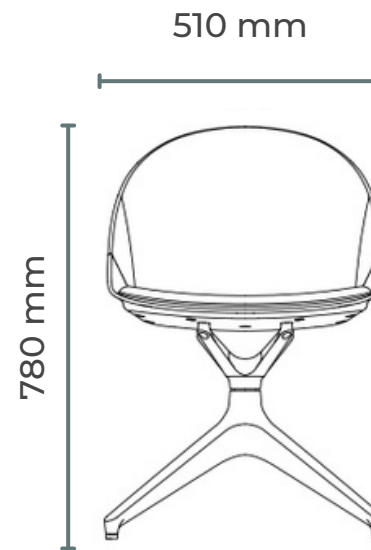
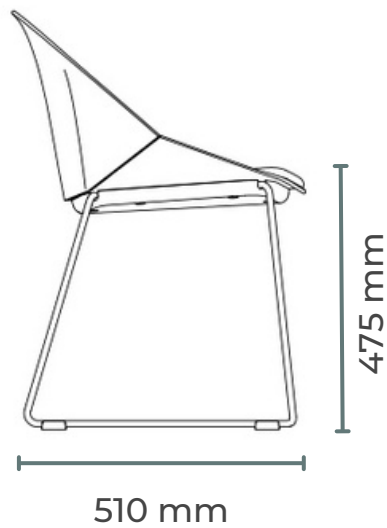
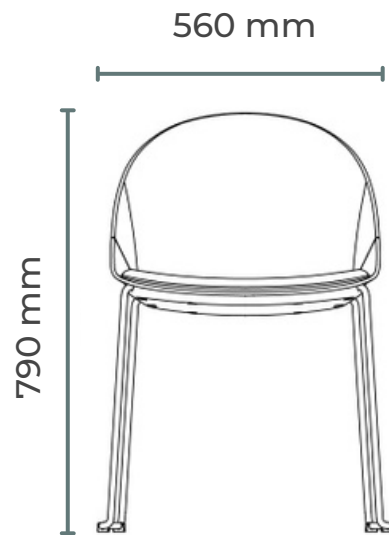
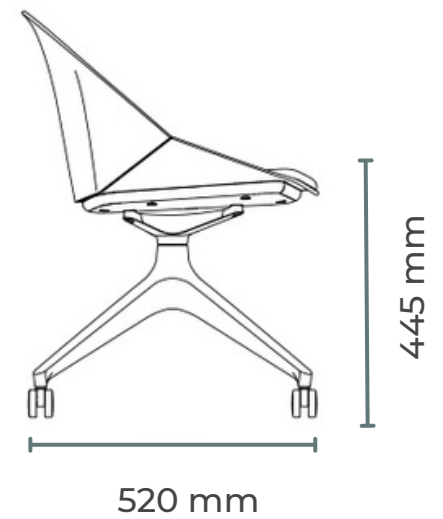
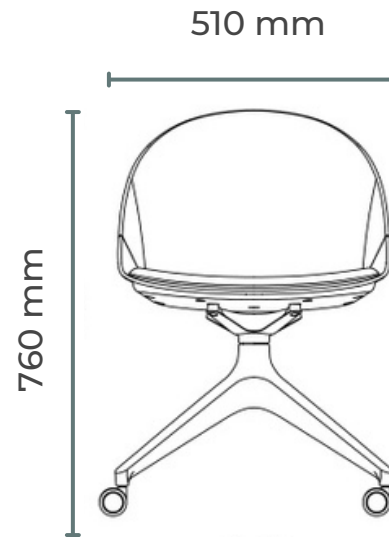
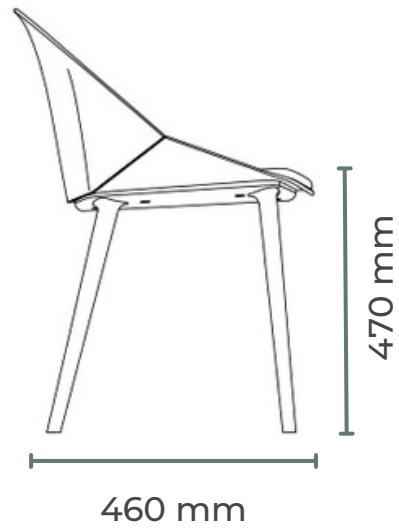
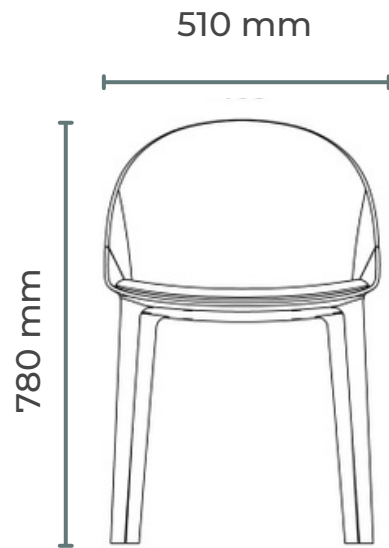

DIMENSIONS

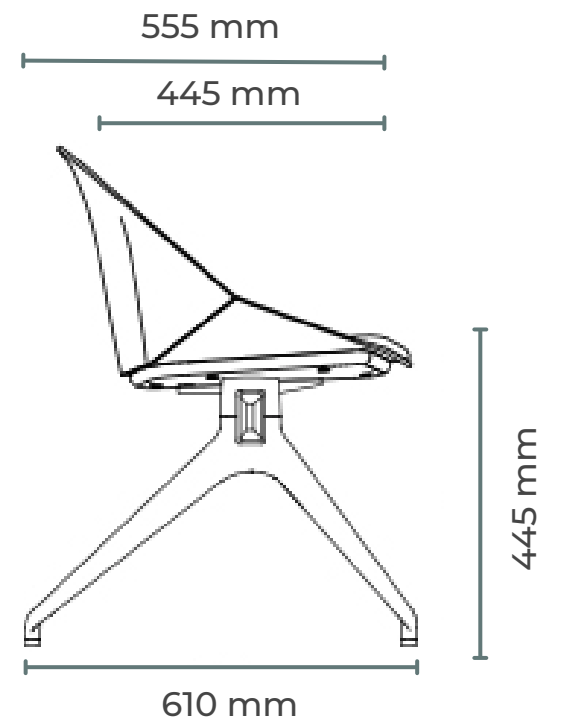
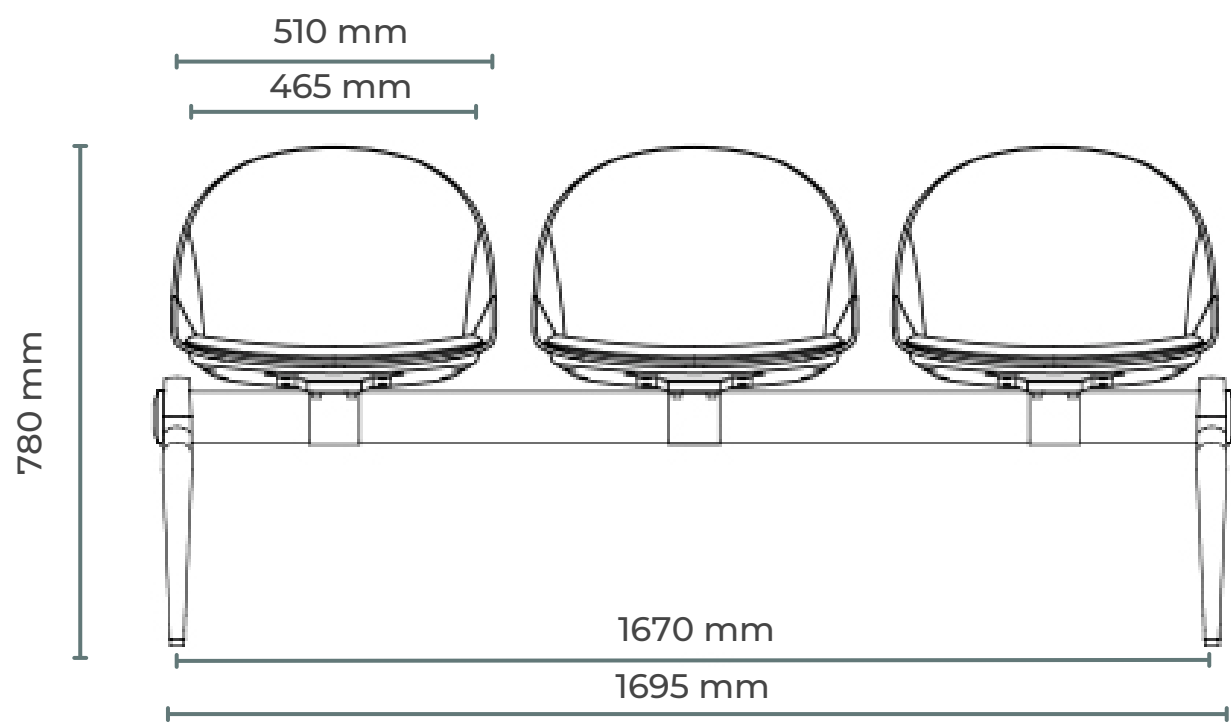
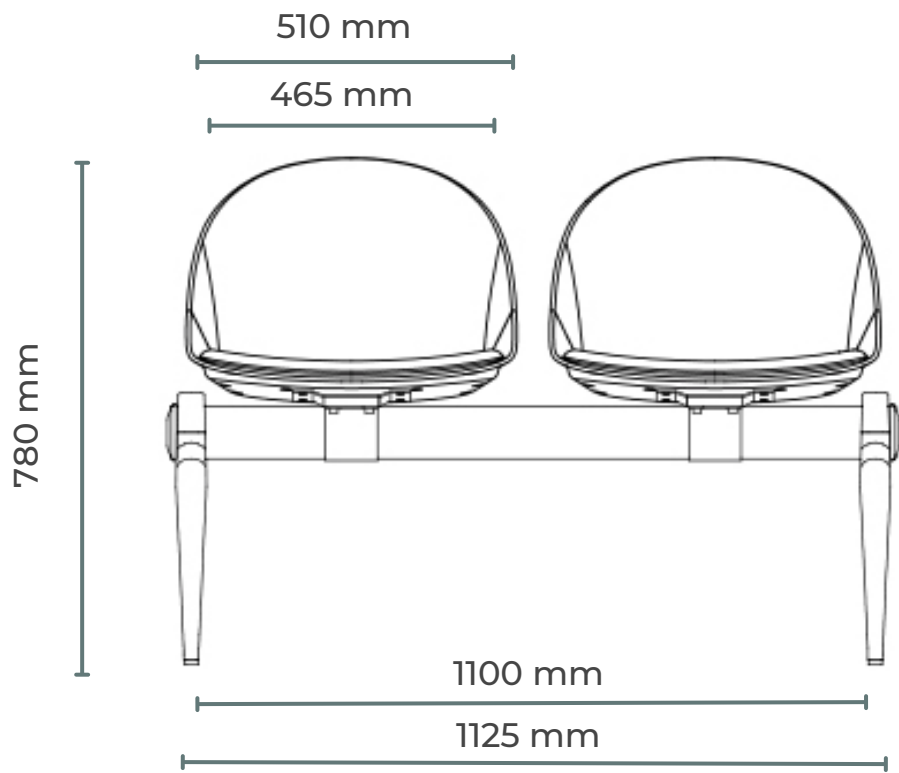

DIMENSIONS

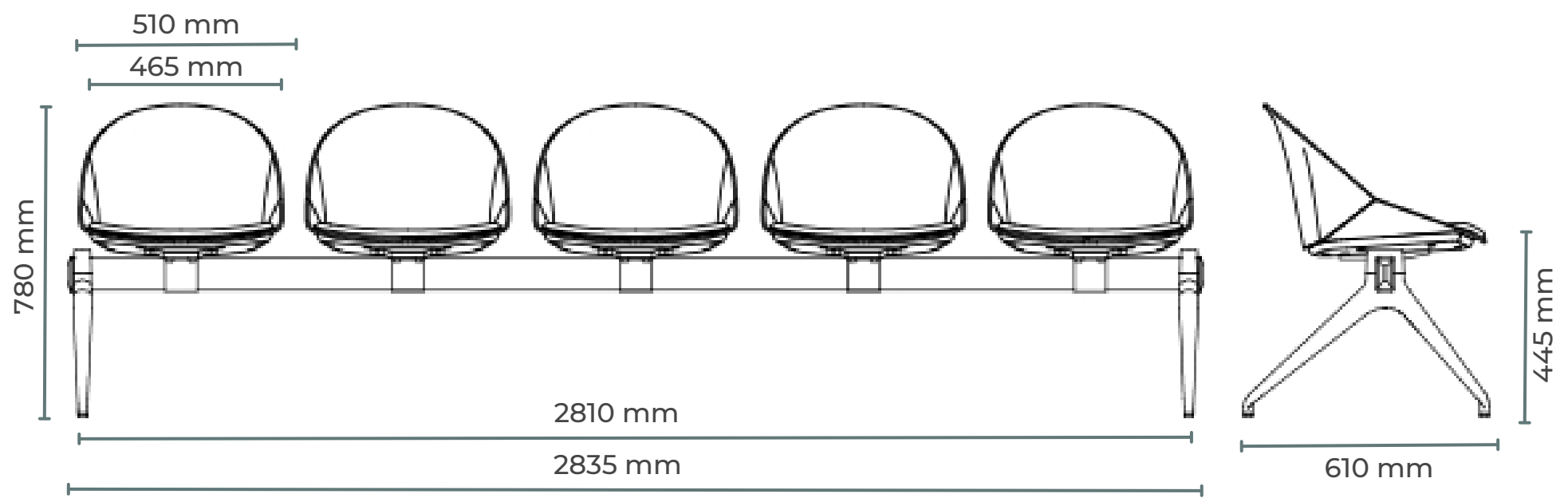
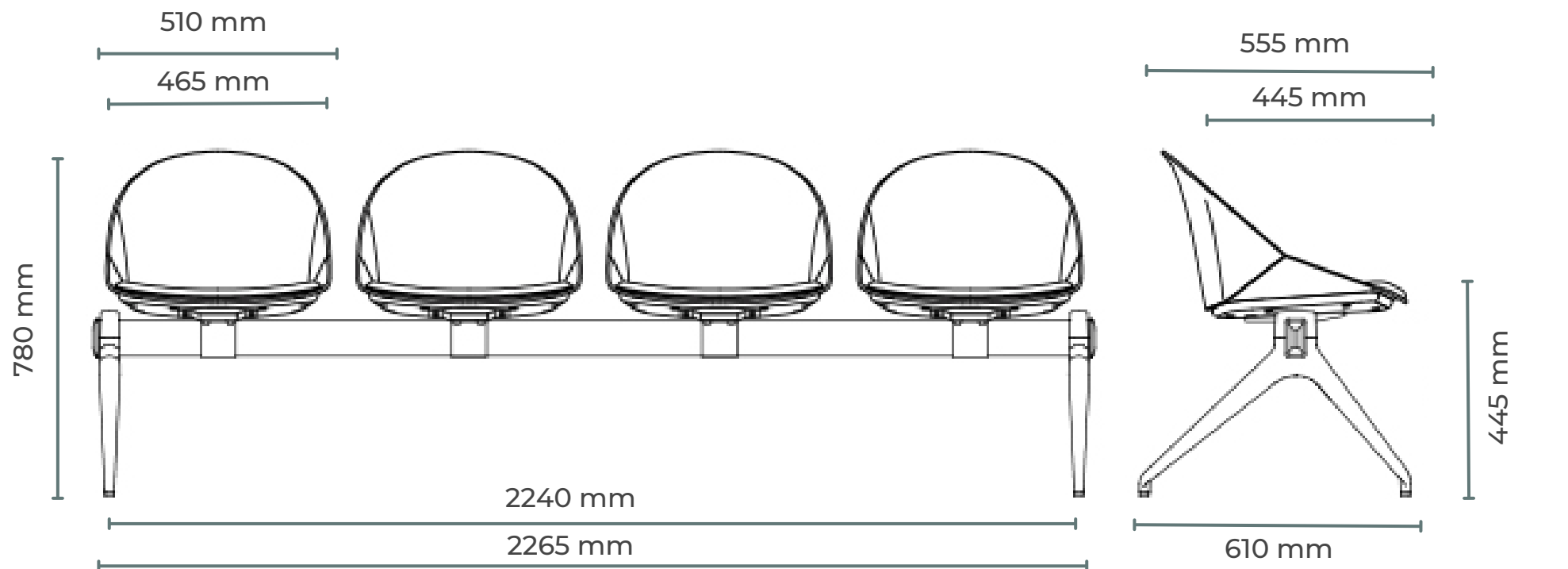

FINISHES

Standard Shell

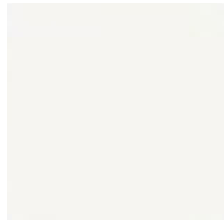

EM WHITE

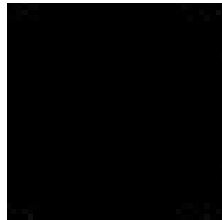

NR BLACK



SC GREEN



SD TEAL



ST ROSE



E7 TAN

Rinasco 100% Recycled Shell

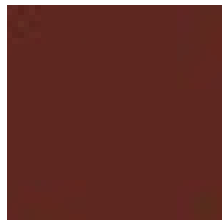

S3 BURGUNDY



S6 GREEN
BROWN

Frame



NR BLACK



SC GREEN



SD TEAL



ST ROSE



E7 TAN



NN

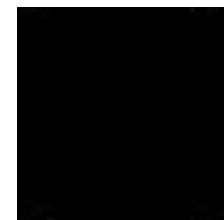

NRR

**Please enquire with sales team for seat pad and upholstery options*

SUSTAINABILITY

Designing new polymers made entirely from recycled materials and imagining a better future. The main intention is to design these newly developed polymers ourselves – and then to manufacture them – instead of using products already developed by others. This has enabled us to join the ranks of those conducting real research in the green sector, to make its contribution to improving this field of study that is so important for the future.

COMPONENTS DERIVED FROM INDUSTRIAL OR CONSUMER WASTE



RECYCLED POLYPROPYLENE (PP)
Minimum 60% recycled materials



RECYCLED POLYAMIDE (PA)
Minimum 30% recycled materials

RINASCO PLASTIC

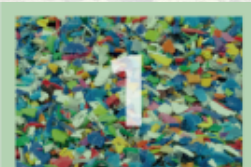

A mixture of recycled materials that include both regenerated polymers of post-industrial and post-consumer origins are collected.



Post-consumer waste comes from selected waste such as packaging, textiles, toys and similar and represents approximately 50% of overall regenerated polymers.



The selected materials are checked and sent to specialist laboratories where they are further examined ensuring it reaches the required quality standards.



The resulting polypropylene is then reinforced with fiberglass and the end-polymer is structurally identical to virgin plastic of the same type (PP-FV).



This material is used for manufacturing chairs and the factory is CSI/IMQ certified as a result of this innovative approach.

WORK SCALE. DESIGN

Unit A, 82 James Carter Road,
Mildenhall Industrial Estate
Suffolk
IP28 7DE
United Kingdom

sales@workscalescale.design



[workscalescale.design](https://www.workscale.design)



0044 20 8068 8098

