

WORK SCALE. DESIGN

Ws.D Snug

SOFAS & BOOTHS





CUSTOMIZABLE

DESIGNED FOR
COMFORT

SUSTAINABLE

Introduction

Page 4

Office Space

Page 7

Canteen space

Page 8

Configurations

Page 9

Accessories

Page 13

Dimensions

Page 14

Finishes

Page 16

Sustainability

Page 19

Configurator

Page 20

Spry

Spry—Seating that moves with you.

Designed for flexibility, Spry adapts to any office setting—offering a blend of comfort, style, and functionality. Whether for collaboration, relaxation, or semi-private meetings, its sleek design and premium materials make it the perfect fit for dynamic environments.



4 INTRODUCTION



Why Ws.D Spry

Modular & Adaptable

12 unique configurations for different workspace layouts.

Comfort & Ergonomics

Supportive foam cushions and high-quality upholstery.

Premium Materials

Steel framework with a choice of static or mobile bases.

Versatile Design

Available in both **low-back** (ideal for open spaces) and **high-back** (semi-private pods for focused meetings).

Sustainable & Durable

Designed for longevity with a recyclable frame and premium fabric options.



INTRODUCTION



A Smart Seating Solution for Work & Welcome

The modern workplace is more than just desks and meeting rooms—it's a space for focus, collaboration, and connection. **Snug** enhances versatility in every workspace corner, whether as a **semi-private pod** for focused work, a **breakout hub** for informal meetings, or a **welcoming seating area** in the reception.

Designed with both **function and style** in mind, Snug's **high-back configurations** create intimate spaces for deep focus or one-on-one discussions, while **low-back versions** encourage open communication and relaxed interactions. In the reception area, Snug leaves a lasting impression, offering guests a comfortable and welcoming experience aligned with your brand identity.

- **Semi-private high-back pods** for focused work and quiet meetings
- **Versatile seating** for breakout areas, team collaboration, and welcoming guests
- **Sleek, modern design** that enhances workspace aesthetics and reception spaces
- **Premium materials & modular design** for durability, flexibility, and long-term use



Snug in the Canteen – A Social Hub

The canteen is more than a place to eat—it's where teams unwind, connect, and recharge. **Snug** transforms dining areas into inviting spaces, featuring **cosy booths** for individuals and **spacious seating for groups**. Its **low-back designs** encourage openness, while high-back pods provide a more intimate, café-style experience.

- **Comfortable & inviting** seating for casual meals or coffee breaks
- **Flexible configurations** for solo diners or group gatherings
- **Durable & stylish** materials built for high-traffic areas

From quick coffee breaks to team lunches, Snug creates a space where people can relax, recharge, and connect. With its adaptable design and inviting comfort, it transforms canteens into social hubs that bring people together.



Designed for Every Space, Built for Every Need

Ws.D Snug Armchair

Low & High Back

- Compact and stylish for focused work or casual seating
- **The low-back** design keeps spaces open and inviting.
- **The high-back** design enhances privacy for quiet moments and focused conversations.



Ws.D Mobile Snug Armchair

Low & High Back

- Easily reposition for dynamic office layouts
- **Low-back** for open seating, **high-back** for added focus
- Perfect for breakout spaces and flexible work areas



Designed for Every Space, Built for Every Need

Snug 2-Seater Sofa

Low & High Back

- Comfortable, stylish, and versatile seating
- **Low-back** blends into social and reception spaces
- **The high-back** design provides an enclosed space for focused discussions.

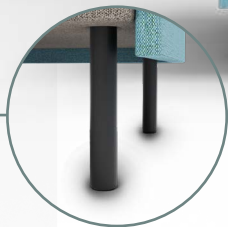

Snug Mobile 2-Seater Sofa

Low & High Back

- Same comfort, even more flexibility
- Easily move and reconfigure spaces as needed
- **Low-back** for open interaction, **high-back** for privacy

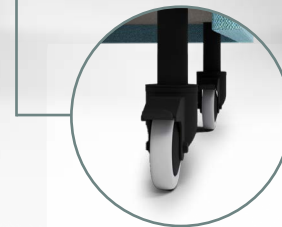

Designed for Every Space, Built for Every Need

Snug 2-Seater Open Meeting Pod

Low & High Back

- Ideal for small meetings or solo focus work
- **High-back** provides semi-private enclosure
- **Low-back** fosters open, engaging conversations



Snug 4-Seater Open Meeting Pod & Fabric Panel

Low & High Back

- A collaborative hub for small teams
- **High-back** creates a defined, private space
- **Low-back** keeps interactions open and fluid for teamwork or dining



2 CONFIGURATIONS



Accessories

Take Snug to the next level with accessories that add **comfort, functionality, and connectivity** to your space.

Bolster cushions – extra comfort

Add support and style with plush cushions in premium **Camira Fabrics**, perfect for posture and relaxation.

TV Wall Bracket – Media-Ready Spaces

Seamlessly integrate screens for **presentations, video calls, or digital displays**, ideal for meeting pods and lounge areas.

Power Supply Attachments – Stay Connected

Keep devices powered with **USB ports, outlets, and smart cable management**, ensuring uninterrupted productivity.

Snug adapts to your needs—customise it with accessories that make every space more **versatile, comfortable, and tech-ready**.

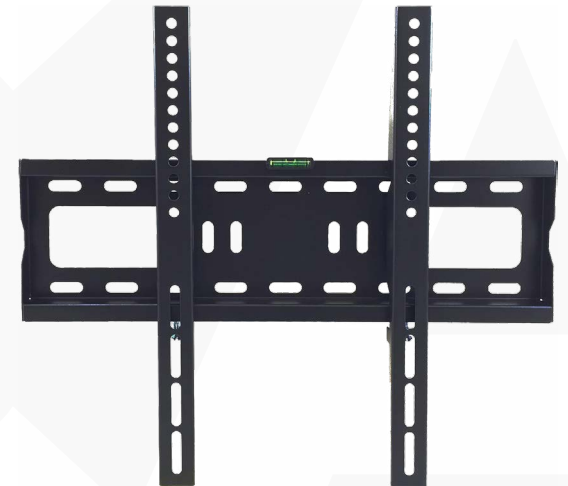

Dimensions

Snug Armchairs

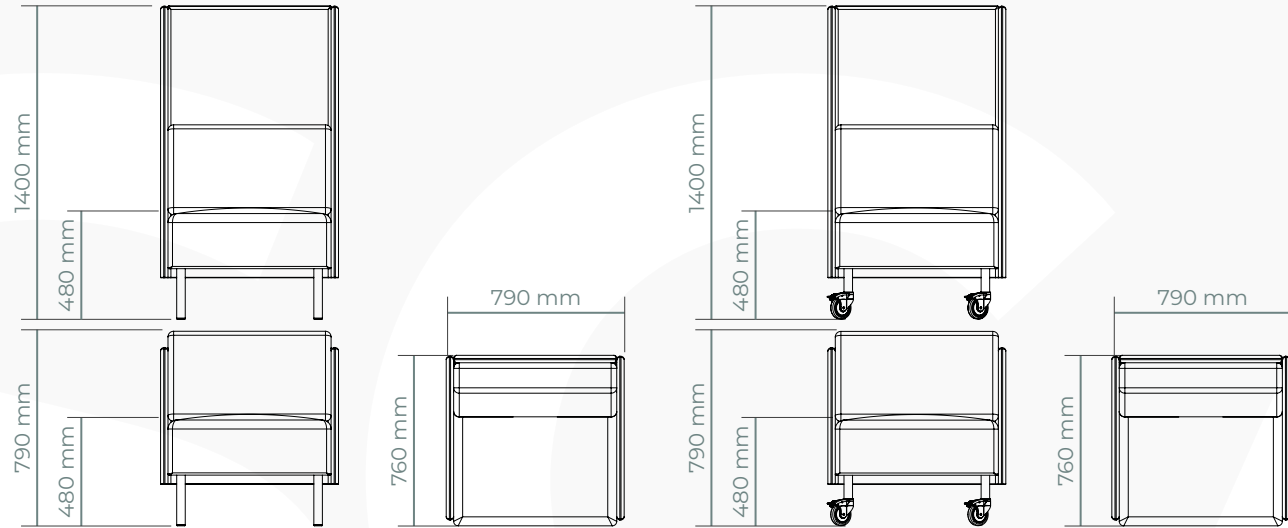

Snug 2-Seater Open Meeting Pod

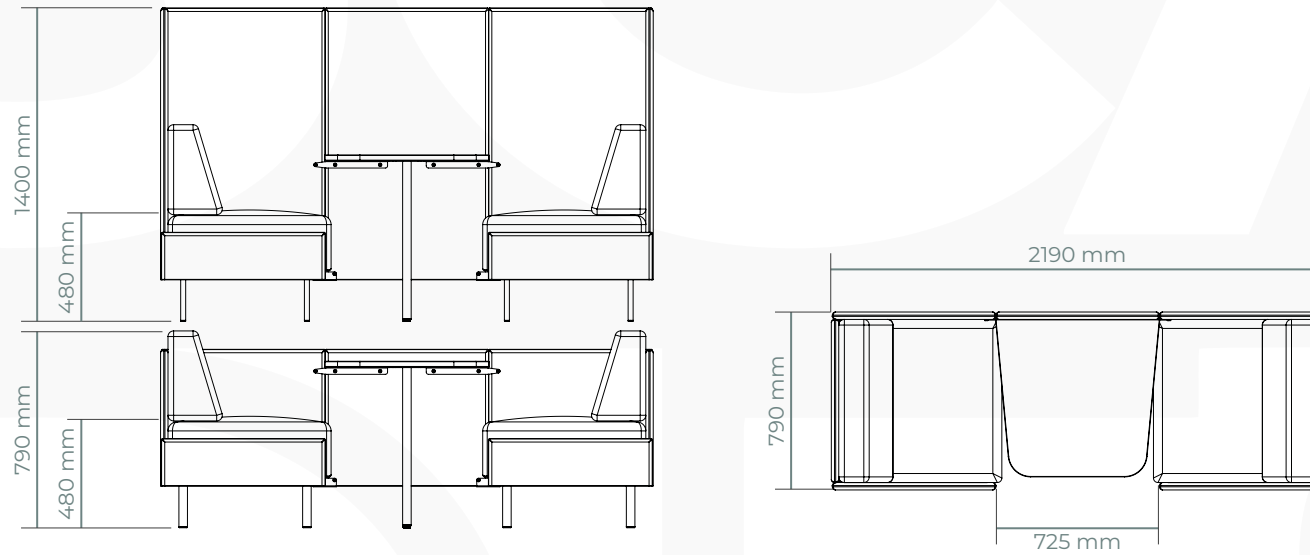

Dimensions

Snug 2-Seater Sofa

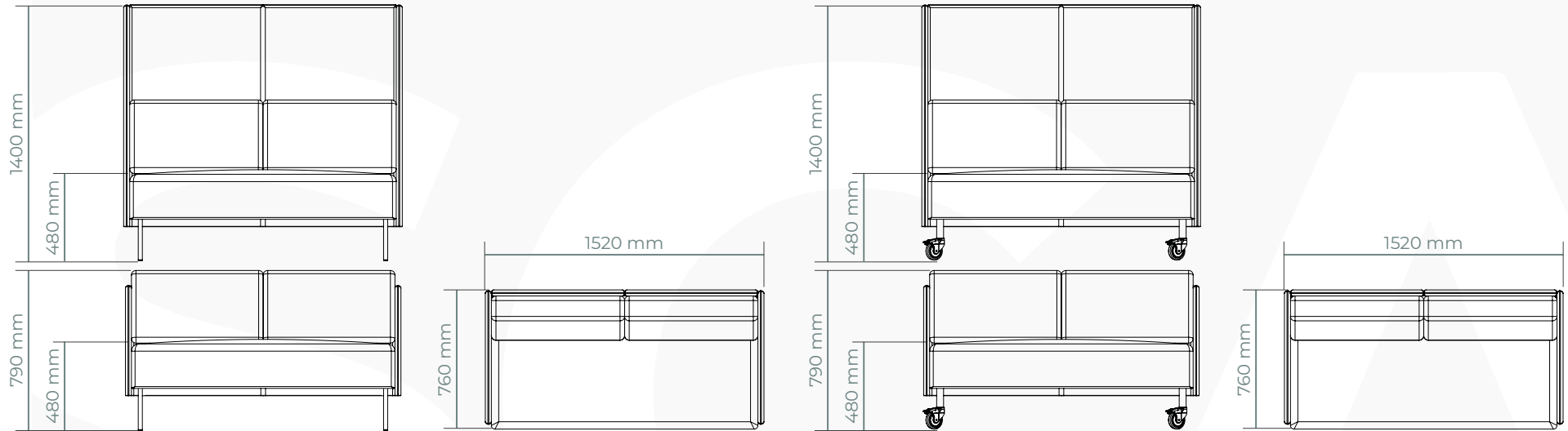

Snug 4-Seater Open Meeting Pod

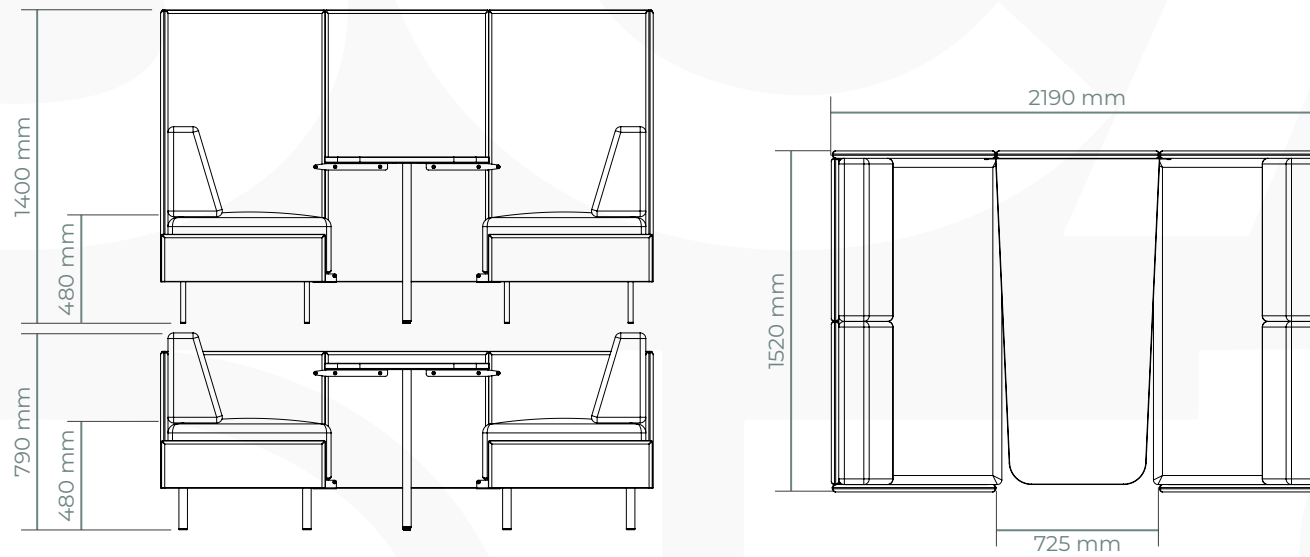

FINISHES

Metal Finishes



Black

MFC Finishes

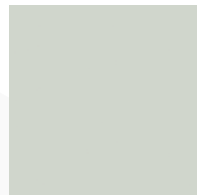

Oppland Green



Espoo Oak

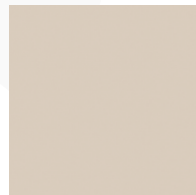

Uppsala Stone



Black

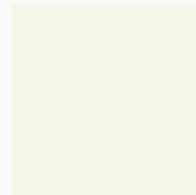

White



Grey



Lava



Birch



Anthracite



Beech



African Oak



Sonoma Oak



Wild Oak



Nut



Ulme Baron



Wenge



Rock Oak



Italian Oak



Coffee Oak

Fabrics

At Workscale.Design, we've carefully selected **Camira Fabrics** to complement **Snug**, ensuring the perfect balance of aesthetics, durability, and sustainability. Each fabric range offers unique textures, finishes, and color options to bring your workspace to life.

Camira Fabric Ranges:

- **Rivet** – A contemporary fabric with a subtle metallic thread that adds a touch of modern sophistication while offering excellent durability.
- **Era** – A timeless, two-tone fabric inspired by classic mid-century design, bringing depth and understated elegance to any space.
- **Xtreme** – A high-performance, stretchable fabric designed for heavy use, making it ideal for busy environments that demand resilience and comfort.
- **Main Line Flax** – A natural wool and flax blend that combines sustainability with a refined, organic aesthetic, adding warmth and texture.



Camira Rivet

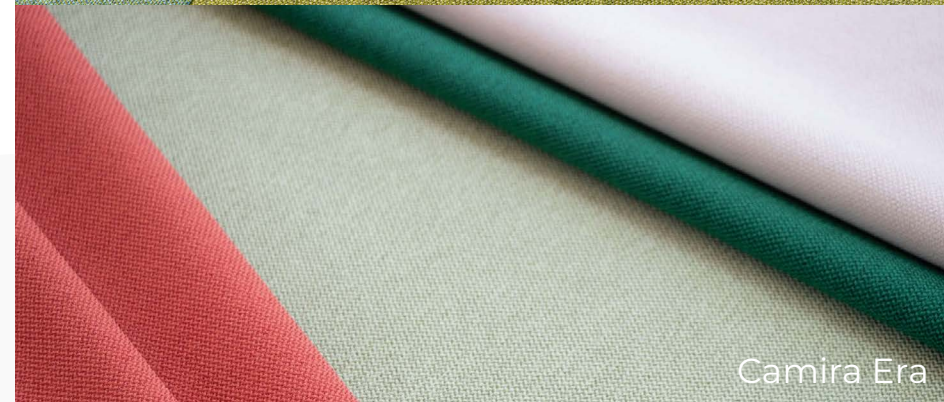

Camira Era



Camira Xtreme



Camira Main Line Flax

- **Synergy** – A luxurious wool-rich blend with a soft touch and a refined finish, designed to elevate both comfort and visual appeal.
- **Silk** – A sophisticated, high-quality wool fabric with a delicate and smooth texture that brings an effortless elegance to any setting.
- **Blazer** – A classic pure wool fabric with a felted finish, offering a premium, tailored look while ensuring long-lasting durability.

Camira fabrics are known for their **eco-conscious production, rich textures, and exceptional craftsmanship**, making them the ideal choice for Snug.

Want to see the options up close? Visit our **configurator** to explore swatches and customise your perfect Snug seating solution.



Camira Synergy



Camira Silk



Camira Blazer

SUSTAINABILITY IN MOTION

At Workscale.Design, sustainability is at the core of our design philosophy. **Snug** is crafted with eco-conscious materials and responsible manufacturing to reduce environmental impact while ensuring long-term durability.

Thoughtfully Sourced Materials

Snug is built using **recycled and recyclable materials**, ensuring a lower environmental footprint. Over **50% of its metal components** come from recycled sources, and all steel, plastic, and wood elements are **fully recyclable** at the end of their lifecycle.

For our **MFC panel finishes**, we source only **FSC®-certified materials**, guaranteeing they come from responsibly managed forests. This certification ensures strict sustainability standards are met, protecting biodiversity and supporting ethical sourcing.

Low-Impact Manufacturing

Snug is produced with **lean manufacturing techniques** that **minimize material waste** and **reduce energy consumption**. Precision laser cutting and a **closed-loop powder-coating system** further lower emissions, ensuring an environmentally responsible production process.

Built to Last, Designed to Adapt

Snug's **modular, durable design** extends its lifespan, reducing waste and ensuring it adapts to the changing needs of your workspace. By choosing **FSC-certified materials, recyclable components, and energy-efficient production methods**, Snug supports both **workplace functionality and environmental responsibility**, helping you create a **more sustainable**, future-ready workspace.



CONFIGURATOR

Click and Customise

Create your perfect seating solution with the **Snug Configurator**. Choose from **12 versatile configurations**, personalise upholstery, and select finishes to match your workspace.

Tailor your selection

Pick Your Configuration – Armchairs, sofas, and open meeting pods in low- or high-back options.

Match Your Style – Select from premium **Camira Fabrics** in a range of colours and textures.

Real-Time Visualisation

3D Preview – Instantly see your design before ordering.

Seamless Integration – Download 3D files for collaboration.

Snug is designed for **comfort, flexibility, and style** - start customising now!

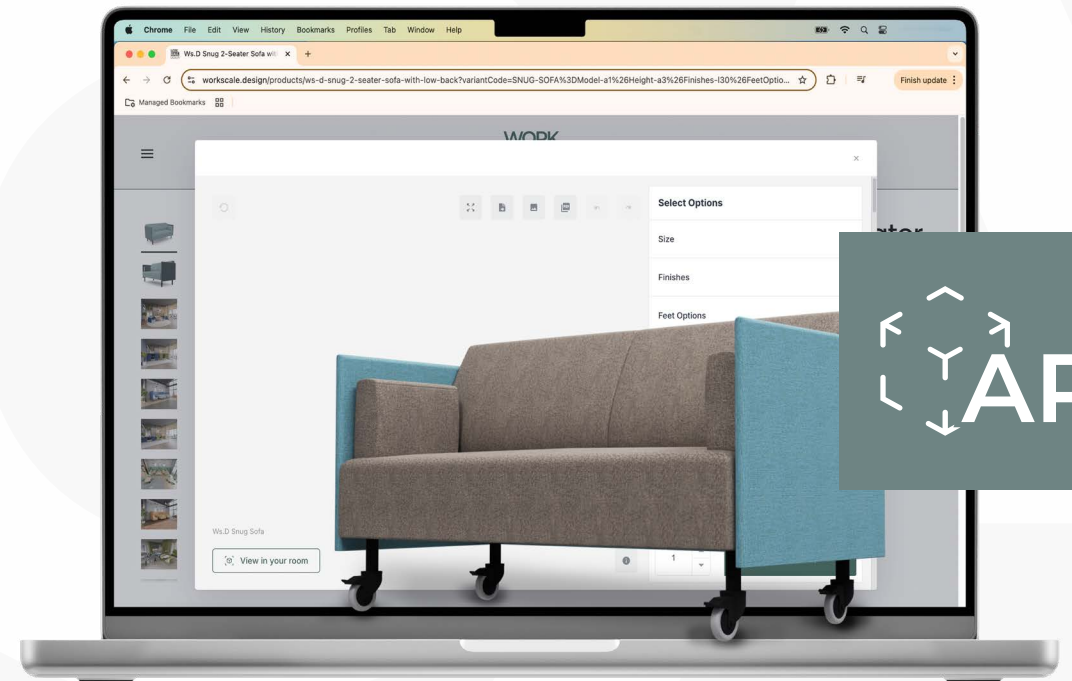

READY TO BRING YOUR VISION TO LIFE? VISIT **Workscale.Design** AND START CREATING TODAY!

WORK SCALE. DESIGN

Unit A, 82 James Carter Road,
Mildenhall Industrial Estate
Suffolk
IP28 7DE
United Kingdom



sales@workscale.design



workscale.design



0044 20 8068 8098